

# **Vertical centrifugal in-line pumps**

Installation and operation instructions  
series: DPNL



# EC declaration of conformity

DP-Pumps  
Kalkovenweg 13  
2401 LJ Alphen aan den Rijn, The Netherlands  
Tel: (+31)(0)-172-48 83 88

Hereby declares as manufacturer entirely on his own responsibility, that the products:

**Vertical single-stage centrifugal pumps, series: DPNL**  
**Horizontal single-stage centrifugal pumps, series: DPNT and DPNM**  
**Horizontal single-stage split case pumps, series: DPAS**

to which this declaration refers, are in accordance with the following standard: **EN 809/A1** according to the provisions of the harmonized standard for pumps and which implies the regulations of **Machine Directive 2006/42/EC, EMC Directive 2004/108/EC, Ecodesign Directive 2009/125/EC, Regulation 547/2012 (for water pumps with a maximum shaft power of 150kW)** in the most recent form.

The pump is subject to this declaration of conformity as a stand-alone product. An installation in which the pump is built in must be declared as compliant to all relevant regulations and standards for the complete



Alphen aan den Rijn  
14/02/2013

Authorized representative  
W. Ouwehand, technical director

## Table of contents

<b>1</b>	<b>Introduction</b> .....	<b>5</b>
<b>2</b>	<b>Important safety precautions</b> .....	<b>6</b>
<b>3</b>	<b>General</b> .....	<b>7</b>
3.1	Definition of pump and applications .....	7
3.2	Performance information .....	7
3.3	Warranty conditions .....	7
3.4	Test .....	7
3.5	Pressure limit .....	7
3.6	Ecodesign .....	8
<b>4</b>	<b>Safe operating conditions</b> .....	<b>9</b>
4.1	Training of personnel .....	9
4.2	Hazardous conditions that may occur when one does not comply with the safety instructions .....	9
4.3	Safety measures for operator .....	9
4.4	Safety measures for maintenance and installation .....	9
4.5	Spare parts replacement .....	9
<b>5</b>	<b>Technical information</b> .....	<b>10</b>
5.1	Design .....	10
5.2	Construction of pump group .....	10
<b>6</b>	<b>Transport and storage</b> .....	<b>11</b>
6.1	Transport.....	11
6.2	Storage .....	11
<b>7</b>	<b>Assembly / installation</b> .....	<b>12</b>
7.1	Installation .....	12
7.2	Coupling alignment .....	12
7.3	Coupling alignment of DPNL pumps supplied without motor or dismantled motor... ..	12
7.4	Piping .....	14
7.5	Motor connection.....	15
<b>8</b>	<b>Commissioning, start up and operating</b> .....	<b>16</b>
8.1	Prestart up check list.....	16
8.2	Checking rotation direction .....	16
8.3	Start-up procedure .....	16
8.4	Shut down procedure .....	17
<b>9</b>	<b>Maintenance</b> .....	<b>18</b>
9.1	Checks during operation .....	18
9.2	Service .....	18
9.3	Spare parts.....	19
<b>10</b>	<b>Noise level and vibration</b> .....	<b>20</b>
10.1	Expected noise values .....	20
<b>11</b>	<b>Disassembly, repair and reassembly</b> .....	<b>21</b>
11.1	Disassembly.....	21
11.2	Reassembly .....	21
<b>12</b>	<b>Possible failures, causes, solutions</b> .....	<b>22</b>

---

<b>13</b>	<b>Pump dimensions table and weights .....</b>	<b>23</b>
<b>14</b>	<b>Tightening torques .....</b>	<b>26</b>
<b>15</b>	<b>Forces and moments at the pump flanges .....</b>	<b>27</b>
<b>16</b>	<b>Typical piping.....</b>	<b>28</b>
<b>17</b>	<b>DPNL sectional drawing and spare part list.....</b>	<b>28</b>
<b>18</b>	<b>DPNL exploded view (without coupling) .....</b>	<b>30</b>
<b>19</b>	<b>DPNL exploded view (with coupling).....</b>	<b>31</b>

# 1 Introduction



This manual contains instructions for the installation, operation and maintenance of the DPNL type non-self-priming centrifugal in-line pumps from DP-Pumps.

- Please read carefully this manual and apply all the instructions to operate pumps without problems. Pumps shall be used for their intended duties. In this manual, there are information on operating conditions, installation, starting-up, settings and main controls of pumps.
- These operating and maintenance instructions contain DP-Pumps' suggestions. The special operating and maintenance information of the plumbing that a pump is fitted to is not considered in these instructions. This information must be given by plumbing constructors only.
- Please refer to instructions of plumbing constructors.
- Please pay attention to the warnings in this manual and ensure that it is read before the installation-start up process. DP-Pumps is not responsible for the accidents resulting from negligence.
- If you cannot find an answer to your questions in this manual, it is suggested that you contact DP-Pumps. Please inform us about the rated value and especially the serial number of the pump when you get in contact for help.
- The safety instructions in this manual cover the current national accident protection regulations. Beside all of these, an operation, work and safety measure imposed by the customer has to be applied.

## The signs used in this operating manual



Read the instructions carefully in this operating manual and store it for future reference.



Warning sign against electrical risks.



Sign for the operator's safety.

## 2 Important safety precautions



In order to minimize the accidents during the mounting and putting into service of the pump, the following rules have to be applied.

1. Do not work without taking safety measures relevant to equipment. Cable, mask and safety band must be used when necessary.
2. Be sure there is adequate amount of oxygen and there is no toxic gaseous around.
3. Before using welding or any electrical equipment make sure that there is no risk of explosion.
4. Check the cleanliness of the area to take care of your health. (Dust, smoke, etc.)
5. Do keep in mind that there is a risk of having accidents related to electricity
6. Do not lift the pump before you check the transport equipment.
7. Be sure you have a by-pass line.
8. Use helmet, eye glasses and protective shoes for your safety.
9. Place a protective barrier around the pump within the necessary safety area.
10. Dust, liquids and gaseous that may cause overheating, short circuit, corrosion and fire must be kept away from the pump unit.
11. By checking the noise level of the pump unit, take necessary measures to avoid noisy operation of the pump that can have harmful effects on the personnel and environment.
12. Be careful about the direction of transport and storage.
13. Cover appropriately the moving parts to avoid possible injury of the personnel. Mount the coupling guard and belting before starting-up the pump.
14. All the electrical and electronic applications must be performed by authorized person conforming EN 60204-1 and/or domestic instructions.
15. Protect the electrical equipment and motor against overloading.
16. If flammable and explosive liquids are pumped, ground connection of electricity should be carried out properly.
17. Do not expose the pump unit to sudden temperature variations.
18. All personnel who work with the waste water system need to be vaccinated in case of contagious diseases.
19. If the pump contains hazardous liquids, one must use protective helmet against the risk of splatter. One also must accumulate the liquid in a proper container against any risk of leakage.

**All other health and safety rules, laws and regulations must be applied.**

# 3 General

## 3.1 Definition of pump and applications

DPNL series pumps are single stage, in-line volute type pumps. They are used in

- Water networks and pressurization facilities
- Irrigation, sprinkling and drainage systems
- Filling and draining of tanks and reservoirs
- Hot and cold water circulation in heating and cooling systems
- Condense water pumping
- Water circulations in pools
- Health and purification facilities
- Industrial and social facilities
- Fresh and sea water pumping in ships

They shall be used to pressurize liquids (up to 90°C), which are clean or mildly impure, non-abrasive, and not containing large solid particles or fibre.





**CAUTION**  
Please contact DP-Pumps for liquids that have different chemical and physical specifications.

DPNL pumps comply with DIN 24255 standards within nominal capacity range.

### Technical specifications of DPNL type pumps

Suction Flange	DN 40-DN 250
Discharge Flange	DN 40-DN 250
Capacity	2-700 m <sup>3</sup> /hour
Head	2-70 m
Speed	900-3600 rpm

### Pump Label

duijvelaar pompen   dp pumps	
Type: P/N: S/N:	Q: m <sup>3</sup> /hr H: m Imp Ø: mm
n: rpm Pmax: bar Tmax: °C	η bep: % MEI: Year:
dp industries Alphen aan den Rijn, Holland	

## 3.2 Performance information

Actual performance of the pump can be obtained from the order page and/or from the test report. This information is given on the pump label. The performance curves given in the catalogue are valid for water whose density and viscosity are  $\rho=1 \text{ kg/dm}^3$  and  $\nu=1 \text{ cst.}$  respectively. For those liquids whose densities and viscosities are different from those of water, please consult with DP-Pumps since the performance curves vary with density and viscosity.



**CAUTION**  
Do not operate the pump with a motor that has a different power except for the given catalogue and label values.

## 3.3 Warranty conditions

The entire products in our selling program are warranted by DP-Pumps. The warranty period is 24 months after delivery.

Warranty conditions will only be valid when all the instructions about installation and start-up operations of the pump unit are taken into account.

## 3.4 Test

All Pumps are dispatched for sale when all the performance and pressure tests are completed. Proper assurance of material and fault-free operation of pumps whose performance tests are made is under the warranty of DP-Pumps.

## 3.5 Pressure limit



Pressure at the discharge flange must not exceed 10 bar. A special order is necessary for applications with higher pressures.

---

## 3.6 Ecodesign

Product according to Regulation 547/2012 (for water pumps with maximum shaft power rating of 150 kW) to the Ecodesign Directive 2009/125/EC.

- Minimum Efficiency Index: See pump label.
- The reference value MEI of a water pump with the best efficiency is = 0.70.
- Year built: See pump label.
- Manufacturer's name or trademark, official registration number and place of production: See manual or order documentation.
- Information about type and size of the item: See pump label.
- Performance curves of the pump, including efficiency characteristics: See documented curve.
- The efficiency of a pump with a corrected impeller is usually lower than that of a pump impeller with a full diameter. A pump with a corrected impeller is adapted to a certain duty point, thereby reducing the energy consumption. Minimum Efficiency Index (MEI) refers to the full impeller diameter.
- The operation of this water pump at different operating points can be more efficient and more economical when it is controlled, for example using a variable speed controller which adjusts the pump operation to the system.
- Information for disassembly, recycling or disposal after the final shutdown: See chapter 11 Disassembly.
- Information about the efficiency reference value or MEI = 0.7 (0.4) benchmark index for the pump on the basis of the pattern in the picture, please visit:  
<http://www.europump.org/efficiencycharts>.



## 4 Safe operating conditions

This manual contains main safety instructions for the installation, operation and maintenance. It must be read by the personnel who are responsible for installation and operation. This manual should always be kept near the installation location. It is important to comply with safety precautions stated in page 1 along with the general safety instructions as well as preventive measures repeated in other sections of this manual.

### 4.1 Training of personnel

Installation, operation and maintenance personnel must have necessary knowledge in order to accomplish the given job. The responsibility, adequacies and controlling duties of such personnel must be determined by the costumer. It has to be certain that these personnel comprehend totally the content of the operating manual.

If the personnel do not have enough knowledge, required training must be given by the costumer. If training support is needed by the costumer, it will be provided by the manufacturer/seller.



**CAUTION**  
**Untrained personnel and unwillingness to comply with safety instructions may be risky for both machine and environment.**  
**DP-Pumps is not responsible for this kind of damages.**

### 4.2 Hazardous conditions that may occur when one does not comply with the safety instructions

Incompliance with safety regulations may put the personnel, the environment and the machine in danger and thus may cause damages. Incompliance with safety regulations may give rise to situations listed below:

**Important operational functions of the factory may stop.**

**Maintenance may get difficult.**

**One may get injured by electrical, mechanical or chemical hazards.**

### 4.3 Safety measures for operator

Dangerous, hot or cold components in the pump area must be covered so that one cannot touch them.

Moving components of the pump (such as rigid coupling) must be covered so that one cannot touch them. Those covers must not be dismantled while the pump is running. Dangers that results from electrical connections must be removed. To get more information about this subject, we refer to VDE and domestic electrical instructions.

### 4.4 Safety measures for maintenance and installation

The costumer must assure that all maintenance, check and instalment tasks are performed by qualified personnel. Repair work must only be performed while the machine is not running. The pump and its auxiliary system must be cleaned thoroughly if it contains hazardous liquids. At the end of the repair work, all safety and protective equipment must be re-installed.

### 4.5 Spare parts replacement

Replacement of spare parts and all modifications must be done after contacting with the manufacturer. Spare parts and accessories certified by the manufacturer are important for the safe operation of the system.

**Notice:** DP-Pumps is not responsible for using improper spare parts.

# 5 Technical information

## 5.1 Design

Single stage, non-self-priming in-line centrifugal pumps are furnished with standard pumps and mechanical seals.

### 5.1.1 Locations of flange - flanges

Discharge Flanges	DIN 2533-PN 16
Suction Flanges	DIN 2533-PN 16

### 5.1.2 Connection of pump and motor

Motor is close coupled to the pump with a rigid coupling using an adapter and flange. In this way, the shafts of the motor and pump constitute a complete unit.

### 5.1.3 Impeller

The closed radial type impeller of the pump is balanced dynamically in an electronic balance machine. The thrust (axial force) is balanced with the back wear ring and balance holes.

### 5.1.4 Shaft

The shaft, impeller and other parts of the pump is designed to be dismountable without moving (dislodge) the suction and discharge pipes and volute of the pump. In this way, the installation and maintenance operations can be performed very easily.

### 5.1.5 Bearing and lubrication

Rolling bearings are not used in DPNL type pumps. Motor bearing is enough for countervailing all axial and radial forces.

### 5.1.6 Seals

In standard production, various mechanical seal types (e.g., bellow type, spring actuated type) are used for sealing.

## 5.2 Construction of pump group

### 5.2.1 Drive

A hermetic, 3 phase, totally enclosed, fan cooled, squirrel caged, IM 3611 V 18 type electrical motor which complies with DIN EN 60034-1, IEC, VDE and standards is used to drive the pump in proper speed and power.

Specifications of electrical motor

- |                  |               |
|------------------|---------------|
| Isolation class  | : F           |
| Protection class | : IP 54-IP 55 |
| Frequency        | : 50 Hz.      |
| Running type     | : S1          |
| Start-up type    | :             |
- 3x380 V(Y) up to 4 kW
  - More than 4 kW, 3x380(Δ) + (Y/ Δ)

### 5.2.2 Coupling and coupling guard

In DPNL type pumps, a clamped type rigid coupling is used. A coupling guard is provided in accordance with EN 294 in the rigid coupling area.



**Pump can only be run with a coupling guard in accordance with EN 294 according to the safety instructions.**

# 6 Transport and storage

## 6.1 Transport

Pump and pump group must be carried safely to the installation location by lifting equipment.



### CAUTION

Current general lifting safety instructions must be applied. Please use a suspension system shown in figure while you are carrying and lifting the pump unit. The suspension rings may be broken because of the excessive load and may result in a damage of the pump. Prefer fabric cable for suspension.

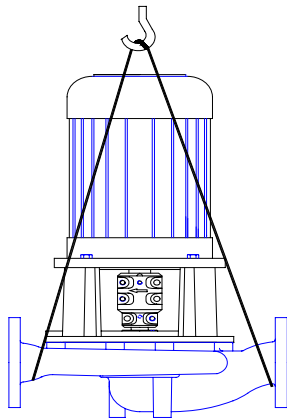

Figure 1 Transport of pump group

Incorrect lifting may damage the pump unit and cause injuries.

### Damages caused in transport

Check the pump when it is delivered to you. Please let us know if there is any damage.

## 6.2 Storage



Please keep the unit clean and dry area during storage.

If the pump is out of use for a long time, please consider the instructions below.

1. If there is water inside the pump, drain it.
2. Clean the pump casing and impeller by jetting clean water for a short time.
3. Empty water inside the pump casing, suction line and discharge line.
4. Add small amount of antifreeze inside the pump casing if it is not possible to empty it completely. Rotate the pump shaft by hand to mix the antifreeze.
5. Close the suction and discharge exits with gasket.
6. Spray an anti-corrosive into the pump casing.
7. Rotate the pump shaft by hand once in every month, in order to protect it from freezing and to lubricate the bearings.

# 7 Assembly / installation

## 7.1 Installation

DPNL type close coupled in-line pumps are mounted to the ground by the foots of the volute casing.

### 7.1.1 Location of installation

Pump shall be installed in a location where the control and the maintenance of the pump are easily made. The pump room shall be suitable for operation of lifting systems such as freight elevator, forklift, etc.

The pump group should be installed in the lowest possible location of the pumping system in order to achieve the highest suction pressure.

### 7.1.2 Location of installation - local ambient temperature

When the local ambient room temperature exceeds +40°C in a pumping system, suitable ventilation should be provided in order to remove the heat dissipated to the environment and supply fresh air.

## 7.2 Coupling alignment

### 7.2.1 General

Since DPNL type pumps are close coupled, they are provided mostly with a motor. The shafts of the motor and the pump are coupled with a rigid coupling and all of the necessary alignments are performed at the factory. Therefore, the coupling alignment is not necessary for DPNL pumps provided with a motor. However, if for any reason the pump and the motor are separated (i.e., rigid coupling is dismantled), it is necessary to re-align the coupling in installation.

### 7.3 Coupling alignment of DPNL pumps supplied without motor or dismantled motor

1. Unscrew the rigid coupling bolts with, take apart the coupling halves from each other.
2. Hook up motor shaft upper part of the coupling, and then fix the motor from flange holes into its place.

3. Push the rigid coupling upward (to the motor side) with a screwdriver or a similar tool (Figure 2-a.)

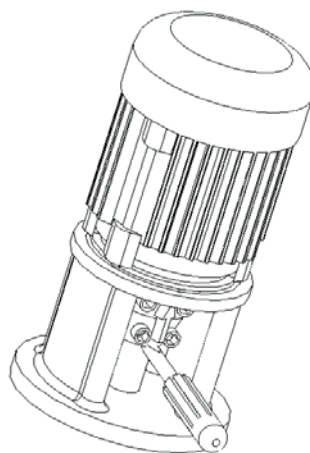

Figure 2-a

4. Using a gauge stick, align the distance between coupling and the adapter. After placing the gauge stick, push the coupling downward (in pump direction).

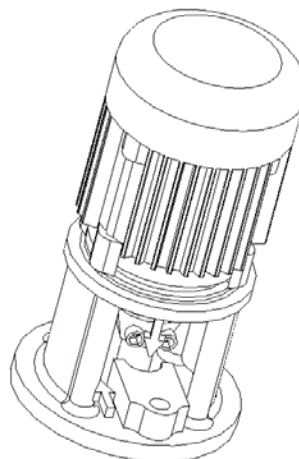

Figure 2-b

5. After aligning the distance of the coupling, screw each bolt by applying equal torque. When the screwing is done, the openings in two sides of the rigid coupling should be equal.

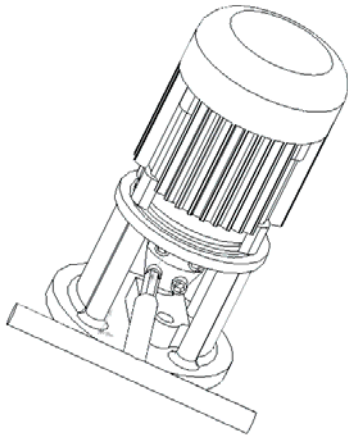

Figure 2-c

6. Dismantle the volute of the pump.
7. Bring the group formed by parts other than the volute in a vertical direction so that the motor stays below. This way, the pump impeller stands at the very top and open
8. Connecting a magnetic comparator to the adaptor as shown in Figure 3, check the shaft and face runout on the front wear ring. In this way, the maximum allowable shaft runout shall be 0.05 mm. If the runout is more than the maximum allowable value, by loosening the bolts of the rigid coupling a little bit and then hitting slightly the shaft nut, ensure that shaft runout is removed. Then, screw the rigid coupling bolts securely. At this instance, you can also align the position of the impeller in the axial direction

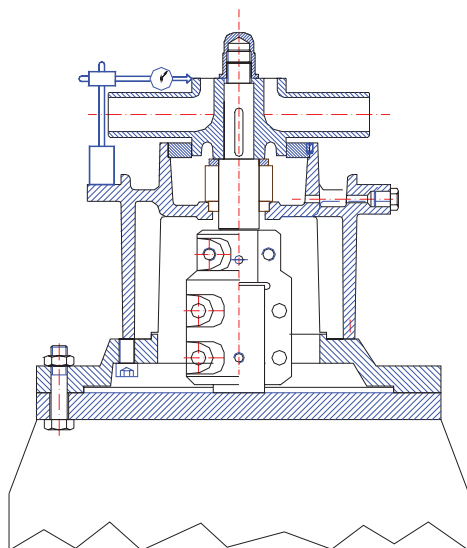

Figure 3

9. If you do not achieve sufficient correction after this alignment, dismantle also the impeller and using a comparator check the runout of the pump shaft in a similar way.

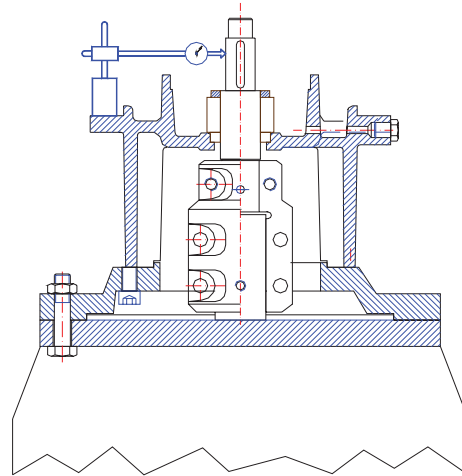

Figure 4

10. By mounting impeller again, check the runout once more and screw the coupling bolts.
11. Position the volute into its place and fix it. By manually rotating the shaft make sure that the shaft rotates easily. Finally, place the pump in the horizontal position.



**After the coupling has been fixed, mount a coupling guard. According to the accident prevention regulations, all preventions and protective devices related to rotating parts shall be in their intended place and in operational form.**

## 7.4 Piping

### 7.4.1 General



**Do not use the pump as the hinged support for the piping system.**

- Put enough supports under the piping system in order to carry the weight of the pipe and fittings.
- Avoid piping system loads on pump by installing flexible components (compensator) to suction and discharge of the pump.
- By mounting flexible supporting items, take into consideration the fact that these items may elongate under the pressure. Especially, the supporting items shall be placed in the direction of discharge flange axis of the pump (generally in vertical direction).
- Suction pipe shall be in a constantly increasing slope to the pump. Air in the suction pipe shall be arranged to move into the pump.
- Discharge piping shall be in a constantly increasing slope to the reservoir or discharge point, without up and downs which can cause air pockets in the piping system. At locations where forming of air pockets is possible, special items like air valve and air cock are mounted to evacuate the trapped air.
- It is important that pipe diameter and fittings are at least as much as the pump opening diameter or preferable one or two size higher. One should never use fittings with smaller diameters than the pump exit diameter. In particular, preferred fittings like foot valve, strainer, filter, check valves and valves shall have large free passing area, and low friction loss coefficient.
- For piping systems with hot liquids, thermal expansions are to be taken into account and compensators shall be mounted in accordance with these expansions. Caution shall be exercised to avoid the loading of pump in this installation.

### 7.4.2 Specification of work in piping installation



**In installation of pipes, follow the procedures below certainly.**

- Take out the guards (placed by the manufacturer) from suction and discharge openings of the pump.
- Close the suction and discharge flanges with rubber gaskets. This precaution is important to avoid the undesired substances (weld crust, weld slag, sand, stone, wood piece etc.) get into the pump. Do not take off this gasket until the installation is completed.
- Start the installation of piping from the pump side. Do the necessary assembling and welding of the parts in a successive order.
- In these operations, do not neglect to put the necessary supports in their respected locations.
- Following above procedure, complete all piping system at suction side up to the suction tank (or foot valve if available), at discharge side up to do discharge collector and discharge pipe.
- When all installation and welding process is done and the heat dissipated by welding is removed, dismantle all the bolted connections from the suction tank to discharge pipe. Take out all demountable parts.
- Clean these parts and then paint body coat completely inside and outside.
- Mount the parts again in their intended places. However, this time start from the discharge line and move downward to the pump. In this instance, do not forget to check the flange gaskets. If needed, (for example deformation during welding) replace them.
- Concerning the connection of the pump flanges to piping, in case of misalignment of axis and flange holes, do not force the system to eliminate the misalignment. Forcing the system may cause difficult-to-correct problems.
- If there is an axial misalignment between the flanges of the pump and the pipe, due to the welding or any other reasons, cut the pipe from a suitable location in order to fix the problem. Connect the pipe (pump side) to the pump. After carrying out the necessary correction, connect the parts again by welding.
- Dismantle and clean the last welded part. Repaint again and mount on its place.
- After all these processes are accomplished, remove the rubber gasket from the suction and discharge openings. Open their holes and mount them again on their intended place.

### 7.4.3 Specification of work after installation of piping and piping system

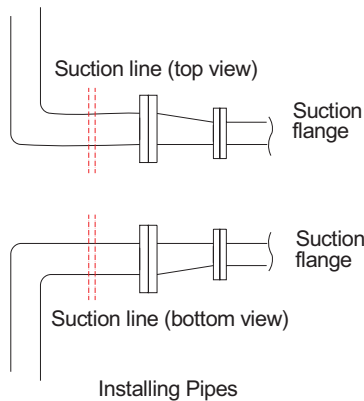

Figure 5 Piping system

An illustrative piping system is shown in Figure 8.



**Complete the auxiliary pipe connections in piping system if exist (cooling to bearing housing, and stuffing box (seal), relief pipe, oil pipe etc.). Appropriate manometers shall be mounted on suction and discharge pipe lines.**

## 7.5 Motor connection

Motor shall be connected by an electrical technician according to the connection (switch) diagram. Local electricity policies and current VDE regulations have to be applied.

- Electrical connections have to be made by authorized electricians.
- In dismantling the pump, make sure the electricity is cut off before taking the motor cover out.
- Use the appropriate electrical connection to the motor.
- In environments where there is a risk of explosion, prescribed protective law and regulations shall be applied by competent authorities.

### 7.5.1 Motor connection diagram



- **Motors requiring high moments at start up shall not be connected star/delta**
- **Frequency controlled motors, require high moment at start up and have to be cooled properly at low speeds. Provide the necessary cooling for the motors.**

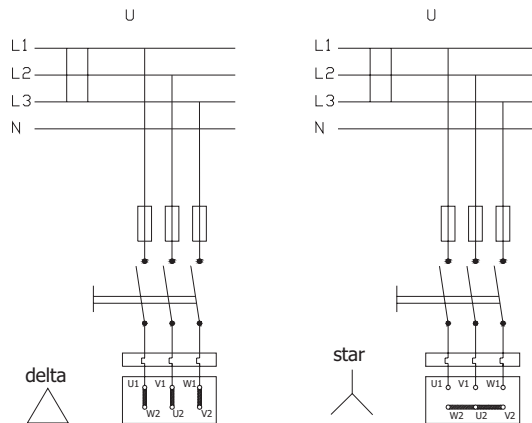

Figure 6 Electric connection diagram

Electrical circuit	Motor	
U (Volt)	230/400V	400V
3 x 230V	Delta	-
3 x 400V	Star	Delta

### 7.5.2 Motor protection

- Three phased-motor shall be connected to power supply.
- Wait the motor to cool down when thermic protected motor breaks in circuit due to the overheating. Make sure the motor does not start automatically until it cools completely.
- In order to protect the motor from overcharging and short circuit use a thermic or thermic-magnetic relay. Adjust this relay to the nominal current of the motor.



**Electrical equipment, terminals and the components of the control systems may carry electric current even though they are not operating. They may cause deadly and serious injuries or irreparable material damages.**

# 8 Commissioning, start up and operating

## 8.1 Prestart up check list

- Make sure that the pump and the suction pipe is completely filled with water before the starting. If the pump operates on a positive suction head, no problem will be encountered. Suction valve is opened and air drains are un-tightened.
- Pumps with foot valve are filled with water by opening the pump filling tap or, one takes advantage of the water accumulated in the discharge pipe and by using a small valve the check valve is bypassed and the pump is filled.
- In vacuum pump driven pumps, by operating the vacuum pump one achieves to fill the pump via increasing the water level in the suction pipe.



**CAUTION**  
Do not start your pump dry.

## 8.2 Checking rotation direction



**CAUTION**  
The direction of rotation is indicated on the pump label with an arrow. Apart from special cases, it is clockwise direction when looking from the motor end. Observe if the pump is rotating in the expected sense by starting the motor for a very short instant. If it is turning in the opposite sense, interchange any of two motor leads.

- If the motor connection is delta, open the discharge valve slowly.
- If the motor connection is star/delta, set the time relay to maximum 5 seconds. Monitor the passage from star to delta by pressing the start button. As soon as you are assured that the connection is delta, open the discharge valve slowly. Continue opening the valve until you read the amperage on the electrical panel.

One should always check the labels which show the direction of rotation and the direction of fluid flow. If you dismount the coupling guard to monitor the direction of rotation, do not restart the engine before remounting the guard.

## 8.3 Start-up procedure

- Check if the suction valve is open and the discharge valve is closed. Start the motor.
- Wait until the motor reaches sufficient speed. (In star/delta connections, wait until the engine passes to delta connection)
- Keeping an eye on the amperage shown on the panel, open the discharge valve slowly.
- In the primary operation, if the discharge pipe is empty, do not open the valve completely. By keeping an eye on the amperage, open the valve with care regarding that it should not exceed the value indicated on pump's label.
- After opening the valve completely, check the pressure from the pump exit manometer and make sure that this value is the pump operating pressure value and is indicated on pump's label.
- If the value one reads is less than the pump label value when the valve is completely open, it means that the height is miscalculated. Increase the value by narrowing the valve and bring it to pump's label value.
- If the value one reads is greater than the pump label value when the valve is completely open, it means that the height is calculated less than what it should be in reality. The device is pumping less than what is requested. Check the installation and the calculations.
- Minimum flow rate: If the pump is working with zero flow rate (closed valve) from time to time during its operation, the water inside the pump may endanger the pump by getting warmed up. In such cases, a minimum flow valve must be connected to the pump exit.



**CAUTION**  
Stop the motor if the pump gets too hot. Wait until it gets cold. Then start the system up again carefully.



## 8.4 Shut down procedure



### CAUTION

During sudden startups and stops, a pressure reducing valve must be placed at the exit section of high flow rate pumps whose discharge pipelines are long, in order to reduce water hammer effect. Water hammer may explode the pump.

In normal conditions (apart from sudden power shut down, etc.), stop the pump as below:

- Close the discharge valve slowly.
- Switch the power off, stop the motor. Notice that the rotor slows down.
- Do not start up the motor at least before 1 to 2 minutes.
- If the pump will be out of use for a long time, close the suction valve and auxiliary circuits. If the pump is outside and if there exists a danger of frost, remove all drain taps and empty all the water inside the pump. See chapter 6 Storage.



### CAUTION

If the pump is outside and if there exists a danger of frost, remove all drain taps and empty all the water inside the pump.

# 9 Maintenance



## CAUTION

**Maintenance operations must be done by authorized personnel with protective clothing only. The personnel must also beware of high temperatures and harmful and/or caustic liquids. Make sure that the personnel reads carefully the manual.**

- The instructions in Safety Precautions must be executed during maintenance and repair
- Continuous monitoring and maintenance will increase the engine's and pump's lives.

## 9.1 Checks during operation

- Pump must never be operated without water.
- Pump must not be operated for a long time with the discharge valve closed (zero capacity).
- Precautions must be taken against flare up when the component temperatures are over 60°C. `Hot Surface` warnings must be placed over necessary areas.
- All the auxiliary systems must be in use while the pump is operating.
- If the pump has mechanical sealing, there is no need for excessive maintenance. Water leakage from the mechanical sealing indicates the fact that the sealing is worn out and therefore needs to be replaced.
- If the system consists of a substitute pump, keep it ready by operating it once a week. Check also the auxiliary systems of the substitute pump.

### 9.1.1 Component check



## CAUTION

**To make possible the visual control, one must be able to reach the pump from any direction. Especially, to be able to dismount the internal units of the pump and the engine, sufficient free space must be created around them for maintenance and repair. Furthermore, one must make sure that the piping system can easily be dismounted**

#### 9.1.1.1 Bearing and lubrication

Rolling bearings are not used in DPNL type pumps. Motor bearing is enough for countervailing

all axial and radial forces. Motor bearings are provided with lifelong heat resistant grease.

### 9.1.2 Mechanical seals

Mechanical seals are used in DPNL type pumps. Mechanical Seals are absolutely leak-proof and needs less maintenance than soft packing.

#### Mechanical seal

- 1) Provides leak-proof operation in heavy operating conditions (in waste water pumps, chemical process and refinery pumps).
- 2) Easily mountable and needs less maintenance.
- 3) Does not cause wearing on the shaft
- 4) Sealing operation does not depend on the quality of shaft finishing.

### 9.1.3 Drive

Apply to the operating instructions of the motor manufacturer.

### 9.1.4 Auxiliary components

Check regularly the fittings and the gaskets, and replace the worn out pieces.

## 9.2 Service

Our Customer Service Department offers after-sale service. Manager should employ authorized and trained personnel for mounting/dismounting procedures. Before these procedures, one must make sure that pump interior is clean and empty. This criterion is also valid for the pumps which are sent to our factory or to our service points.



## CAUTION

**Maintain the safety of the personnel and the environment in every field procedure.**

### 9.3 Spare parts

The spare parts of DPNL type pumps are guaranteed for 10 years by DP-Pumps. In your spare parts requests, please indicate the below listed values that are indicated on your pump's label.

Pump type and size:

Motor power and speed:

Pump serial number:

Capacity and head:

If you wish to keep spare parts in store, depending on the number of same type of pumps, for two operation years, the quantities which are listed in the table below are recommended.

Component name	The number of equivalent pumps in the installation						
	1-2	3	4	5	6-7	8-9	10 +
Shaft (key included) quantity	1	1	2	2	2	3	% 30
Impeller (quantity)	1	1	1	2	2	3	% 30
Mechanical seal	1	2	2	3	3	4	% 50
Wear ring	1	1	1	2	2	3	% 50
Rigid clamped coupling	1	2	2	3	3	4	% 50

# 10 Noise level and vibration

The reasons to increase the noise level are indicated below:

- Noise level increases due to the fact that the pump is not founded properly (vibration).
- If the installation does not have compensator noise and vibration increases.
- Wearing in ball bearing also increases noise level.



## CAUTION

Check if there is any noise increasing elements in your installation.

## 10.1 Expected noise values

Mpower of Motor PN (KW)	Sound Pressure Level (dB) *	
	Pump with Motor	
	1450 rpm/min.	2900 rpm/min.
< 0.55	63	64
0.75	63	67
1.1	65	67
1.5	66	70
2.2	68	71
3	70	74
4	71	75
5.5	72	83
7.5	73	83
11	74	84
15	75	85
18.5	76	85
22	77	85
30	80	93
37	80	93
45	80	93
55	82	95
75	83	95
90	85	95

(\*) Without protective sound hood, measured at a distance of 1 m directly above the driven pump, in a free space above a sound reflecting surface.

The above values are maximum values.  
The surface noise pressure level at dB(A) unit is shown as (LpA). This complies with TS EN ISO 20361.

# 11 Disassembly, repair and reassembly



**Before starting work on the pump set, make sure it is disconnected from the mains and cannot be switched on accidentally.**

**Follow the safety precaution measures outlined in the "safety instructions" section.**

## 11.1 Disassembly

- Close all valves in the suction and discharge lines.
- Remove the safety guard .
- Thanks to "Back Pull Out Design"; the impeller, shaft and other rotating parts being removable no need to disconnect the suction and delivery pipes.
- If to take out the complete pump is necessary, disconnect pump from the driver, suction and discharge pipes and detach the baseplate (if any).
- Dismantle the rotor group with motor from the volute casing. (Be careful to keep the stuffing box cover in place to avoid any mechanical seal trouble).
- Unscrew the end nuts (65) of the impeller and take out the impeller (20) and impeller key (210). Use rust remover solvent if necessary during dismantling.
- Take out the set screws on the pump shaft .
- Take off the motor by unscrew the hex bolts (320).
- Pull out the rotating part of the mechanical seal (250).
- Take out the shaft.

## 11.2 Reassembly

- Reassembly proceeds in reverse sequence to disassembly as described in section F1. You may find the attached drawings useful.
- Coat the seats and screw connections with graphite, silicon or similar slippery substance before reassembly. If you cannot find any of the above you may use oil instead. (Except the pumps for drinking water).
- Never use the old O-rings and make sure the O-rings are the same size as the old ones.
- Slip the pump shaft (60) onto the motor shaft, fix the set screws.

- Place the stationary part of mechanical seal to its place on the adaptor (12)
- Mount the adaptor to the motor flange.
- Slip the rotating part of the mechanical seal onto the pump shaft (61)
- Place the impeller key (210) into keyway, slide the impeller (20) onto the shaft (61) and screw the impeller nuts (65).
- Now reassembly of the rotor group is completed.
- Finally mount rotor assembly to the volute casing. (In the repair shop or on site).
- Make sure the gaskets and O-rings are evenly placed without sliding and not damaged or not squeezed at all.
- Place the pump on the baseplate, couple the motor. Connect suction and discharge pipes as well as auxiliary pipes. Take the unit into operation as described in chapter 8.

# 12 Possible failures, causes, solutions

Possible failures and solution strategies are listed in the table below. Please apply to the Customers' Service Department of our company when a generic solution is not found to your problem.



**While the failures are repaired the pump must always be dry and un-pressurized.**

POSSIBLE FAILURE	CAUSES	SOLUTIONS
1) The pump delivers insufficient capacity	<ul style="list-style-type: none"> <li>Discharge head too high</li> <li>Very high counter pressure</li> <li>Pump and/or pipe cannot discharge air, cannot suck</li> <li>Occurrence of air pockets inside the pipe</li> <li>NPSH is too low</li> </ul>	<ul style="list-style-type: none"> <li>Readjust the operating point</li> <li>See if there is any undesired material inside the pipe</li> <li>Vent completely the pump and the pipe</li> <li>Change the piping configuration</li> <li>Increase the liquid level</li> </ul>
2) Motor overload	<ul style="list-style-type: none"> <li>System pressure is lower than the requested pressure level</li> <li>Speed too high</li> <li>Liquid pumped of different specific gravity and viscosity than that for which pump is rated</li> <li>Engine works at two phases</li> </ul>	<ul style="list-style-type: none"> <li>Adjust the operating pressure to the label value</li> <li>Decrease the speed</li> <li>Increase the engine power</li> <li>Replace the fuse and control the electrical connections</li> </ul>
3) Pump head is too high	<ul style="list-style-type: none"> <li>System pressure is higher than the requested pressure level</li> </ul>	<ul style="list-style-type: none"> <li>Set the operating pressure to the label value</li> </ul>
4) Bearing temperatures are high	<ul style="list-style-type: none"> <li>Worn out coupling</li> <li>Too much, too little or improper lubrication</li> <li>Increase in axial forcing</li> </ul>	<ul style="list-style-type: none"> <li>Replace the coupling</li> <li>Change the oil, decrease or increase its quantity</li> <li>Clean the balance holes on the impeller disc</li> </ul>
5) Excessive leakage from the stuffing box	<ul style="list-style-type: none"> <li>Worn out gland</li> <li>Loose gland</li> </ul>	<ul style="list-style-type: none"> <li>Use brand new gland</li> <li>Change the stuffing bush</li> <li>Tighten the gland nuts</li> </ul>
6) Noisy operation	<ul style="list-style-type: none"> <li>Worn out motor or pump ball bearings</li> <li>Cavitation</li> <li>Worn out or misaligned coupling</li> <li>Operation in the far left or right of the performance curve</li> </ul>	<ul style="list-style-type: none"> <li>Replace</li> <li>Close the delivery partially in order to reduce the capacity.</li> <li>Replace the coupling or align it</li> <li>Operate the pump at its label setting</li> </ul>
7) Excessive increase in pump temperature	<ul style="list-style-type: none"> <li>Pump and/or pipe can neither discharge, nor aspirate air</li> <li>Too low capacity</li> </ul>	<ul style="list-style-type: none"> <li>Bleed completely the pump and the pipe</li> <li>Open more the valve</li> </ul>
8) Vibration	<ul style="list-style-type: none"> <li>Pump and/or pipe can neither discharge, nor aspirate air</li> <li>NPSH is too low</li> <li>Internal components of the pump are worn out</li> <li>System pressure is lower than the requested pressure level</li> <li>Coupling is misaligned</li> <li>Too much, too little or improper lubrication</li> <li>Rotor unbalanced</li> <li>Improper bearings</li> </ul>	<ul style="list-style-type: none"> <li>Bleed completely the pump and the pipe</li> <li>Increase the liquid level</li> <li>Replace the worn out components</li> <li>Adjust the operating pressure to the label value</li> <li>Align the coupling</li> <li>In case of continuous overload, decrease the impeller diameter</li> <li>Change the oil, decrease or increase its quantity</li> <li>Balance the impeller again</li> <li>Use new bearings</li> </ul>

# 13 Pump dimensions table and weights

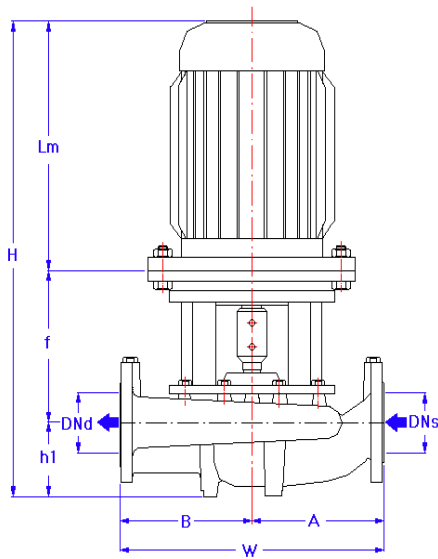

Pump Id. Code	KW	Flange		Dimension (mm)							Mech. Seal.(*)	Weight (Kg)			
		Dimension	Lm	W	H	A	B	H1	f	Nominal Diameter					
DPNL 40-160	/ 34	0,55	DN 40	233	320	473	160	160	80	160	20	39,6			
	/ 54	0,55		233		473							160	20	39,6
	/ 74	0,75		233		473							160	20	40,7
	/ 152	1,5		250		490							160	20	44,4
	/ 222	2,2		275		515							160	20	46,8
	/ 302	3		275		515							160	20	56,3
	/ 402	4		324		584							180	20	66
/ 552	5,5	324	584	160	160	80	180	30	74						
DPNL 40-200	/ 54	0,55	DN 40	233	380	488	190	190	95	160	20	44,6			
	/ 74	0,75		233		488							160	20	45,7
	/ 114	1,1		250		506							160	20	48,5
	/ 154	1,5		275		506							160	20	50,6
	/ 402	4		324		599							180	20	72,5
	/ 552	5,5		324		624							205	30	86
	/ 752	7,5		375		675							205	30	92
/ 1102	11	484	380	809	190	190	95	230	30	155,5					
DPNL 50-160	/ 54	0,55	DN 50	233	360	493	180	180	100	160	20	40,6			
	/ 74	0,75		233		493							160	20	41,7
	/ 114	1,1		250		510							160	20	43,6
	/ 302	3		305		585							180	20	58,3
	/ 402	4		324		604							180	20	68
	/ 552	5,5		375		675							200	30	78
/ 752	7,5	375	360	675	180	180	100	200	30	84					
DPNL 50-200	/ 54	0,55	DN 50	233	400	503	200	200	110	160	20	47,6			
	/ 74	0,75		233		503							160	20	48,7
	/ 114	1,1		250		520							160	20	51,5
	/ 154	1,5		275		545							160	20	53,5
	/ 552	5,5		375		690							205	30	89
	/ 752	7,5		375		690							205	30	95
	/ 1102	11		484		824							230	30	158
	/ 1502	15		484		400							824	200	200



DPNL 50-250	/	154	1,5	DN 50	275	440	570	215	225	115	180	20	67,3
	/	224	2,2		305		600				180	20	70,3
	/	304	3		305		600				180	20	73,7
	/	1502	15		484		829				230	30	180
	/	1852	18,5		528		873				230	30	195
	/	2202	22		544		889				230	30	231
DPNL 65-160	/	3002	30c	DN 50	582	440	927	215	225	115	230	30	257
	/	74	0,75		233		508				160	20	46,2
	/	114	1,1		250		525				160	20	49
	/	154	1,5		275		550				160	20	51,1
	/	402	4		324		619				180	20	71,5
	/	552	5,5		324		639				200	30	82
DPNL 65-200	/	752	7,5	DN 65	375	400	690	200	200	115	200	30	88
	/	1102	11		484		799				200	30	108
	/	0,74	0,75		233		508				160	20	52,7
	/	114	1,1		250		525				160	20	54,5
	/	154	1,5		275		550				160	20	56,6
	/	224	2,2		305		550				160	20	65,3
DPNL 65-250	/	752	7,5	DN 65	375	460	695	230	230	115	205	30	98
	/	1102	11		484		829				230	30	162
	/	1502	15		484		829				230	30	173
	/	1852	18,5		528		873				230	30	188
	/	224	2,2		305		655				215	20	71,3
	/	304	3		305		655				215	20	71,7
DPNL 65-250	/	404	4	DN 65	324	480	674	245	235	135	215	20	82,7
	/	554	5,5		375		750				240	30	104,5
	/	2202	22		544		919				240	30	236,5
	/	3002	30		544		919				240	35	264,5
	/	3702	37		637		1032				260	35	289
	/	4502	45c		637		1032				260	35	317
DPNL 80-160	/	74	0,75	DN 80	233	440	538	220	220	135	170	20	52
	/	114	1,1		250		556				170	20	54,5
	/	154	1,5		275		580				170	20	56,6
	/	224	2,2		305		630				190	20	67,3
	/	552	5,5		324		669					30	84,8
	/	752	7,5		375		720				210	30	94
DPNL 80-160	/	1102	11	DN 80	484	440	859	220	220	135	240	30	158
	/	1502	15		484		859				240	30	169
	/	1852	18,5		528		903				240	30	184
	/	224	2,2		305		625				180	20	69,8
	/	304	3		305		625				180	20	73,2
	/	404	4		324		644				180	20	81,5
DPNL 80-200	/	1502	15	DN 80	484	500	854	250	250	140	230	30	171,5
	/	1852	18,5		528		898				230	30	192
	/	2202	22		544		914				230	30	234
	/	3002	30		637		1037				260	35	299
	/	3702	37		637		1037				260	35	319
	/	304	3		305		665				215	20	88
DPNL 80-250	/	404	4	DN 80	324	550	684	270	280	145	215	20	96
	/	554	5,5		375		735				215	30	116
	/	754	7,5		413		773				215	30	124
	/	554	5,5		375		750				215	30	135,5
	/	754	7,5		413		788				215	30	143,5
	/	904	9		413		788				215	30	152,5
DPNL 80-315	/	1104	11	DN 80	484	600	884	300	300	160	240	30	213
	/	1504	15		528		928				240	30	245
	/	114	1,1		250		565				160	20	60,5
	/	154	1,5		275		590				160	20	62,6
	/	224	2,2		305		640				180	20	74
	/	304	3		305		640				180	20	77
DPNL 100-160	/	752	7,5	DN 100	375	500	740	250	250	155	210	30	100
	/	1102	11		484		879				240	30	164
	/	1852	15		484		879				240	30	175
	/	2202	18,5		528		923				240	30	190
	/	2202	22		544		923				240	30	232



DPNL 100-200	/	224	2,2	DN100	305	550	675	275	275	180	190	30	76,6
	/	304	3		305		675				190	30	83
	/	404	4		324		694				190	30	91
	/	554	5,5		375		770				215	30	114
	/	754	7,5		413		808				215	30	122
	/	904	9		413		808				215	30	131
	/	2202	22		544		947				250	30	246
	/	3002	30		637		1097				280	35	312
	/	3702	37		637		1097				280	35	332
/	4502	45c	637	1097	275	275	180	280	35	354,9			
DPNL 100-250	/	554	5,5	DN 100	375	600	780	320	280	190	215	30	130
	/	754	7,5		413		818				215	30	138
	/	1104	11		484		914				240	30	214
	/	1504	15		528		958				240	30	246
DPNL 100-315	/	1104	11	DN 100	484	650	914	335	315	190	240	30	222
	/	1504	15		528		958				240	30	254
	/	1854	18,5		528		958				240	30	274
	/	2204	22		582		1012				240	30	299
DPNL 125-200	/	304	3	DN 125	305	660	705	350	300	210	190	30	96
	/	404	4		324		724				190	30	104
	/	554	5,5		375		800				215	30	126,5
	/	754	7,5		413		838				215	30	134,5
	/	904	9		413		838				215	30	143,5
	/	3002	30		637		1117				270	35	323
	/	3702	37		637		1117				270	35	343
/	4502	45c	637	1117	300	300	210	270	35	365,9			
DPNL 125-250	/	554	5,5	DN 125	375	650	800	350	300	210	215	30	135
	/	754	7,5		413		838				215	30	143
	/	1104	11		484		934				240	30	218
	/	1504	15		528		978				240	30	250
	/	1854	18,5		544		994				240	30	270
DPNL 125-315	/	1854	18,5	DN 125	544	700	994	370	330	210	240	30	283
	/	2204	22		582		1032				240	30	308
	/	3004	30		637		1112				265	35	386
	/	3704	37c		637		1112				265	35	406
DPNL 150-200	/	554	5,5	DN 150	375	650	780	335	315	190	215	30	152
	/	754	7,5		413		818				215	30	160
	/	1104	11		484		914				240	30	228
	/	1504	15		528		958				240	30	260
DPNL 150-250	/	904	9	DN 150	413	670	818	315	355	180	225	30	168
	/	1104	11		484		914				250	30	235
	/	1504	15		528		958				250	30	267
	/	1854	18,5		544		974				250	30	287
	/	2204	22		582		1097				250	30	312
	/	3004	30		637		1097				280	35	378
DPNL 150-315	/	1854	18,5	DN 150	544	770	1009	390	380	210	255	35	314
	/	2204	22		582		1047				255	35	339
	/	3004	30		637		1132				285	35	416
	/	3704	37c		637		1132				285	35	436



# 14 Tightening torques

Thread Diameter	Tightening Torque Max (Nm)	
	Property Classes	
	8.8	10.9
M4	3.0	4.4
M5	5.9	8.7
M6	10	15
M8	25	36
M10	49	72
M12	85	125
M14	135	200
M16	210	310
M18	300	430
M20	425	610
M22	580	820
M24	730	1050
M27	1100	1550
M30	1450	2100
M33	1970	2770
M36	2530	3560

# 15 Forces and moments at the pump flanges

All of the applied loads if not reached the maximum allowable value, to provide that the following additional conditions, one of these loads may exceed the normal limit:

$$\left( \frac{\sum |F|_{\text{actual}}}{\sum |F|_{\text{maximum allowable}}} \right)^2 + \left( \frac{\sum |M|_{\text{actual}}}{\sum |M|_{\text{maximum allowable}}} \right)^2 \leq 2$$

Any component of a force or a moment, must be limited 1.4 times of the maximum allowable value, The actual forces and moments acting on each flange, should provide the following formula:

In here,  $\sum |F|$  and  $\sum |M|$  are arithmetic sum of the loads for each flange at the pump level, without regard of the algebraic signs of the actual and maximum allowable values.

Pump Type	Forces And Moments						
	Suction and Discharge Flange				Suction and Discharge Flange		
	mm	N			Nm		
	F y	F z	F x	M y	M z	M x	
DPNL 40-160	40	595,3	476,2	523,82	428,58	500,01	619,06
DPNL 40-200	40						
DPNL 40-250	40						
DPNL 50-160	50	785,7	642,9	714,3	476,2	547,63	666,68
DPNL 50-200	50						
DPNL 50-250	50						
DPNL 65-160	65	1000	809,5	880,97	523,82	571,44	714,3
DPNL 65-200	65						
DPNL 65-250	65						
DPNL 80-160	80	1191	976,2	1071,45	547,63	619,06	761,92
DPNL 80-200	80						
DPNL 80-250	80						
DPNL 80-315	80						
DPNL 100-160	100	1595	1286	1428,6	595,25	690,49	833,35
DPNL 100-200	100						
DPNL 100-250	100						
DPNL 100-315	100						
DPNL 125-200	125	1881	1524	1690,51	714,3	904,78	1000
DPNL 125-250	125						
DPNL 125-315	125						
DPNL 150-200	150	2381	1929	2142,9	833,35	976,21	1190,5
DPNL 150-250	150						
DPNL 150-315	150						

Forces at the pump flanges were calculated according to TS EN ISO 5199 standard. The calculations are valid for the materials of cast iron and bronze. Forces and moments at the flanges that made of stainless material will be approximately twice as moments in the table.

# 16 Typical piping

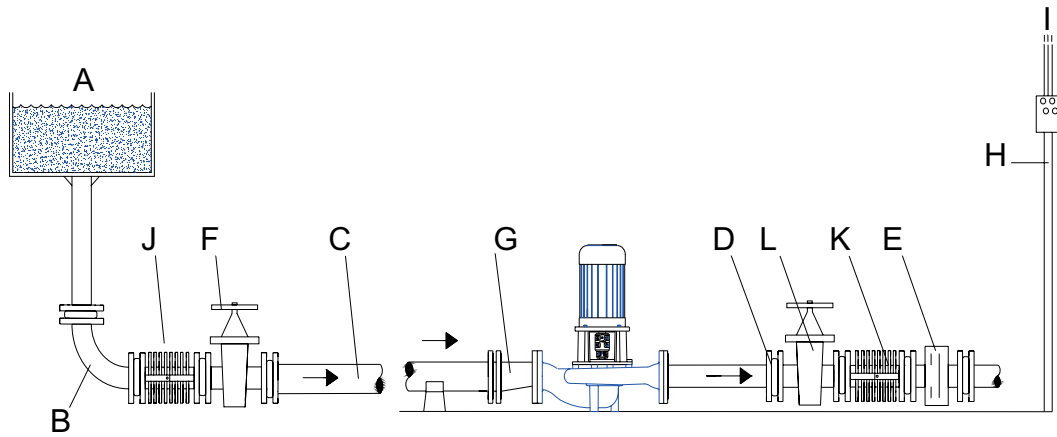
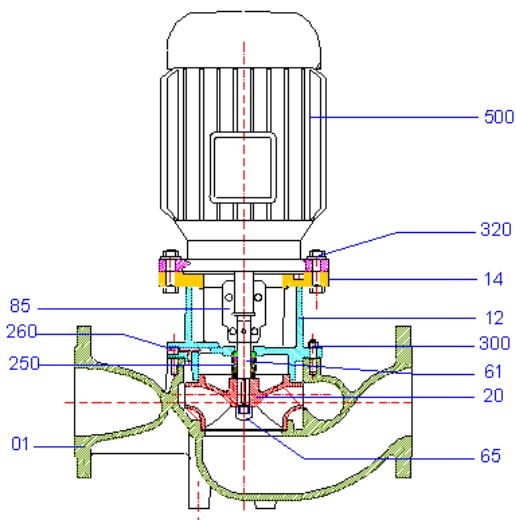

Figure 7 A Typical Piping

- A. Tank
- B. Large radius elbow
- C. Minimum slope is 2 cm/m
- D. Fittings, flanges etc.
- E. Non-return valve
- F. Suction valve
- G. Reducer
- H. Electrical connection
- I. Insulated cable
- J. Compensator
- K. Compensator
- L. Discharge valve

# 17 DPNL sectional drawing and spare part list



Part No	Part Name (Standard pump parts)
01	Volute casing
12	Adapter
14	Motor flange
20	Impeller
61	Shaft
65	Impeller nut
85	Rigid coupling
250	Mechanical seal
260	Plug
300	Casing stud
320	Hex bolt
500	Motor

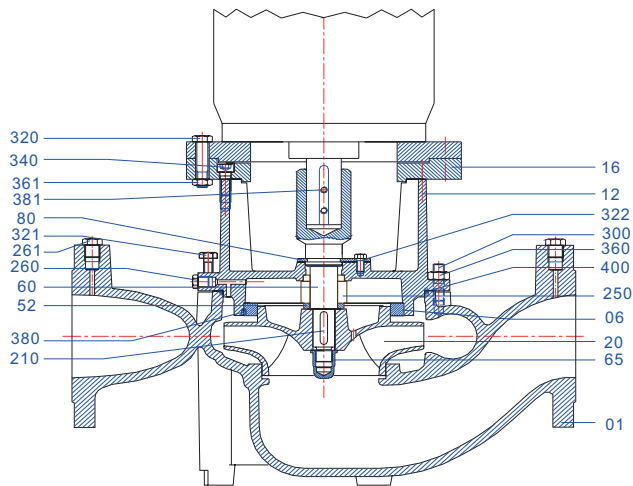

No	Part Name	No	Part Name	No	Part Name
01	Pump Casing	80	Shackle	322	Hex Bolt
06	Wearing Ring	210	Key, Impeller	340	Cap Screw
12	Adapter	250	Mechanical Seal	360	Nut
16	Motor Flange	260	Pipe Plug, Adapter	361	Nut
20	Impeller	261	Pipe Plug, Pressure Gauge	380	Set-Screw
52	Mechanical Seal Ring	300	Stud, Pump Casing	381	Set-Screw
60	Pump Shaft	320	Hex Bolt	400	O-Ring
65	Impeller Nut	321	Hex Bolt		

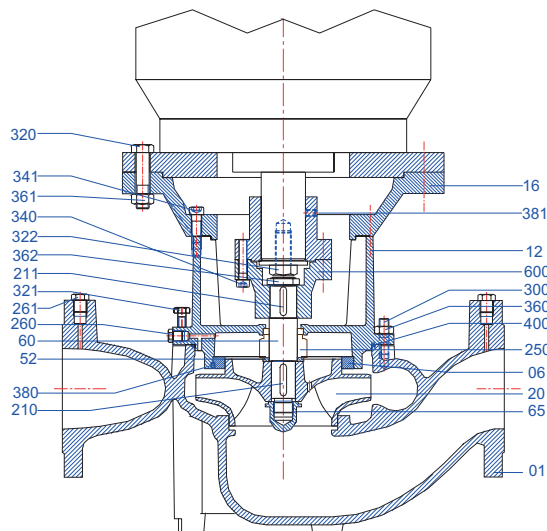

No	Part Name	No	Part Name	No	Part Name
01	Pump Casing	211	Key, Coupling	341	Cap Screw
06	Wearing Ring	250	Mechanical Seal	360	Nut
12	Adapter	260	Pipe Plug, Adapter	361	Nut
16	Motor Flange	261	Pipe Plug, Pressure Gauge	362	Nut
20	Impeller	300	Stud, Pump Casing	380	Set-Screw
52	Mechanical Seal Ring	320	Hex Bolt	400	O-Ring
60	Pump Shaft	321	Hex Bolt	600	Coupling
65	Impeller Nut	322	Hex Bolt		
210	Key, Impeller	340	Cap Screw		

Note: This coupling system is applied with a motor power 30 kW and over.

## 18 DPNL exploded view (without coupling)

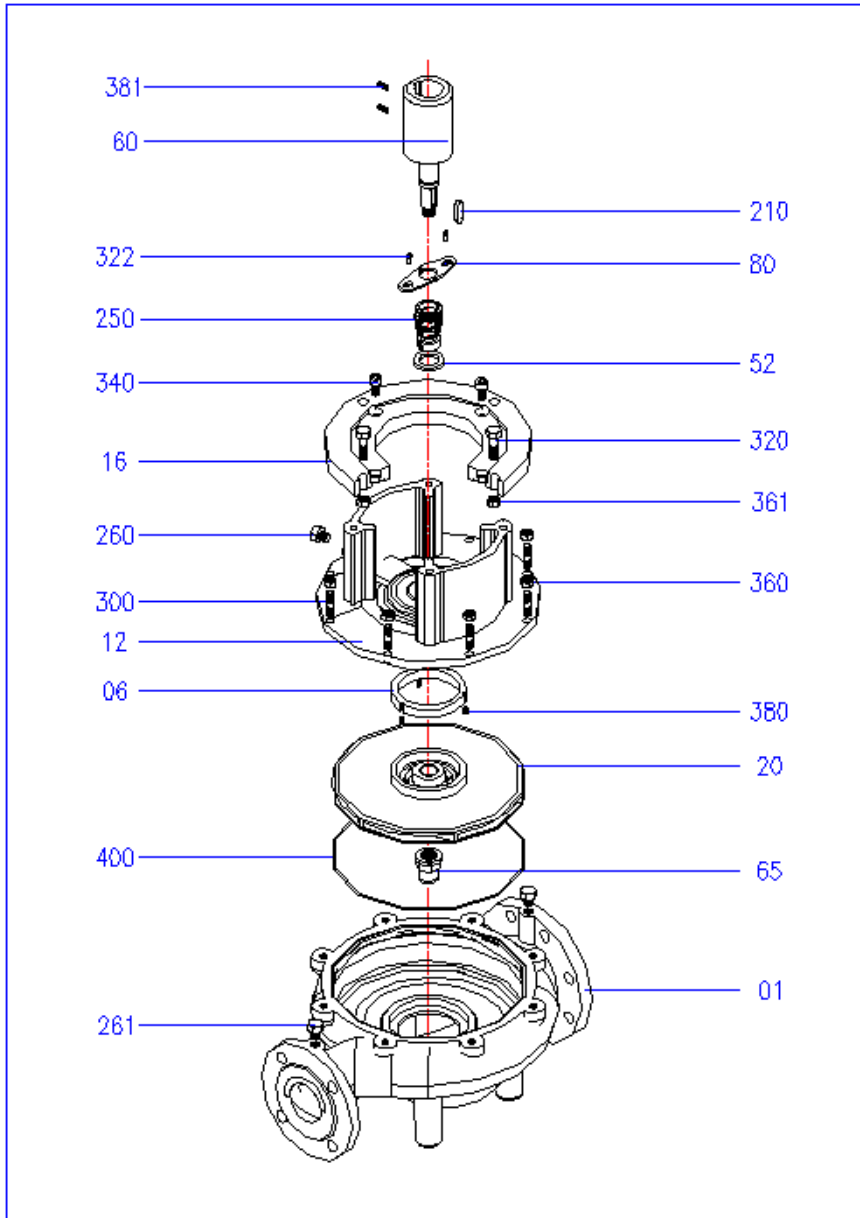

30

No	Part Name	No	Part Name
01	Pump Casing	260	Pipe Plug, Adapter
06	Wearing Ring	261	Pipe Plug, Pressure Gauge
12	Adapter	300	Stud, Pump Casing
16	Motor Flange	320	Hex Bolt
20	Impeller	322	Hex Bolt
52	Mechanical Seal Ring	340	Cap Screw
60	Pump Shaft	360	Nut
65	Impeller Nut	361	Nut
80	Shackle	380	Set-Screw
210	Key, Impeller	381	Set-Screw
250	Mechanical Seal	400	O-Ring

## 19 DPNL exploded view (with coupling)

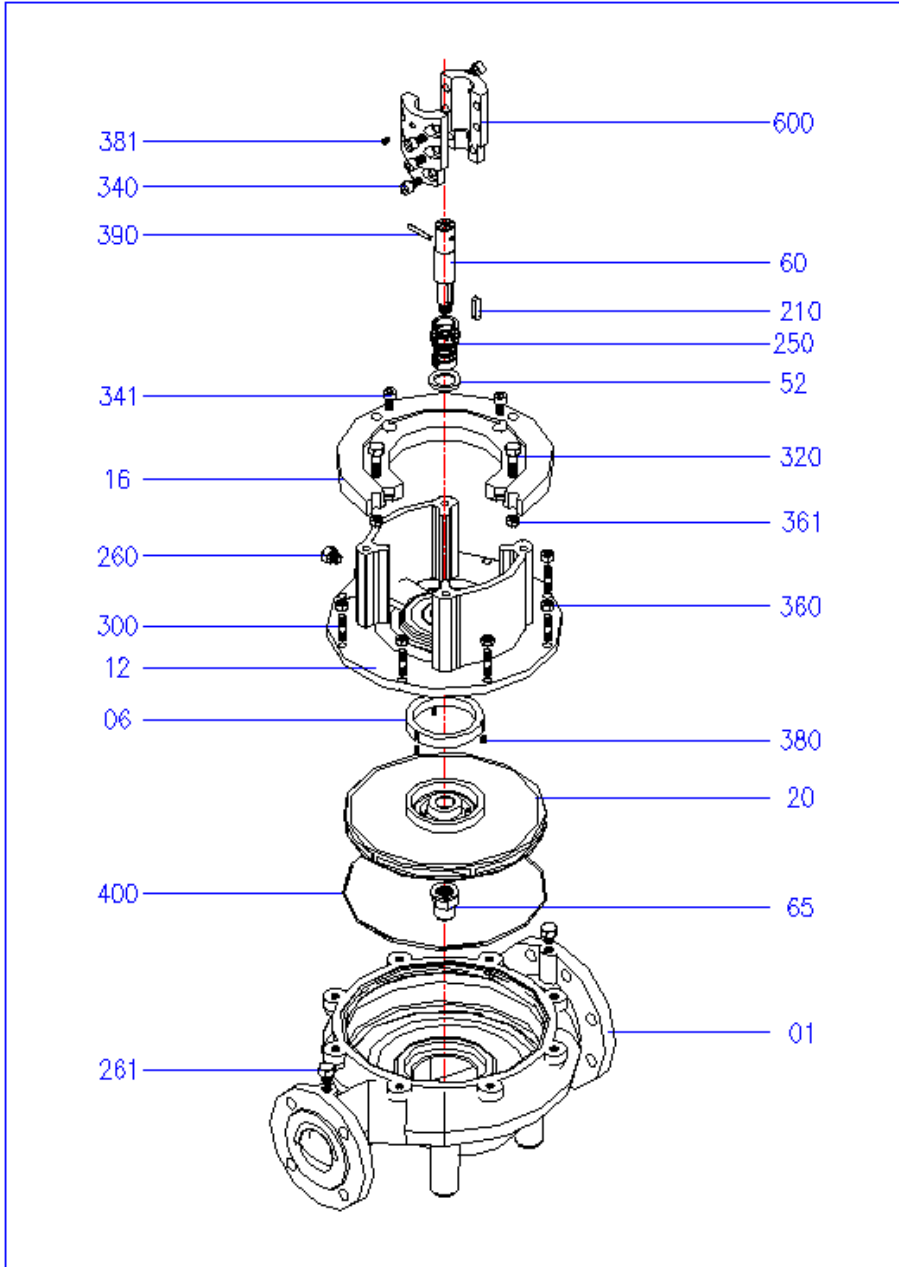

No	Part Name	No	Part Name
01	Pump Casing	300	Stud, Pump Casing
06	Wearing Ring	320	Hex Bolt
12	Adapter	340	Cap Screw
16	Motor Flange	341	Cap Screw
20	Impeller	360	Nut
52	Mechanical Seal Ring	361	Nut
60	Pump Shaft	380	Set-Screw
65	Impeller Nut	381	Set-Screw
210	Key, Impeller	390	Grooved Pin
250	Mechanical Seal	400	O-Ring
260	Pipe Plug, Adapter	600	Rigid Coupling
261	Pipe Plug, Pressure Gauge		

---

## **dp pumps**

**dp pumps**  
P.O. Box 28  
2400 AA Alphen aan den Rijn  
The Netherlands

**t** +31 172 48 83 88  
**f** +31 172 46 89 30

[dp@dp.nl](mailto:dp@dp.nl)  
[www.dp.nl](http://www.dp.nl)

03/2013

Can be changed without prior notice  
Original instructions

