

GD-41G, GD-43G

Direct type	Pilot type	Piston	Diaphragm
Bellows	Internal sensing	External sensing	Stainless steel
With handle	Built-in strainer	Low pressure	Remote
Valve leakage 0	Nylon		

■Features

- Space saving and resource saving are achieved (used materials are shown on the body and lower cap, thus separate collection of parts for resource recycling is easy).
- Stainless steel (SCS14A and SUS316) is used for wetted parts, improving corrosion resistance.
- PTFE covers diaphragm contact surface to fluid, making the diaphragm less liable to deteriorate and highly durable.
- Special fluorine-contained rubber parts are resistant to corrosion.
- Pressure balance structure can keep the reduced pressure at a constant level without being affected by inlet pressure.
- Can be applied to piping washing, system washing, sterilization washing and steam for sterilization.
- Horizontal or vertical installation is available.



GD-41G

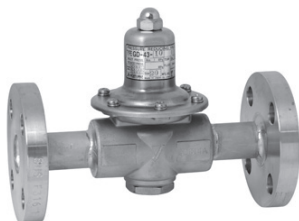

GD-43G

■Specifications

Model	GD-41G	GD-43G-10	GD-43G-20
Application	Air, Carbon dioxide gas, Nitrogen gas Steam for washing or sterilization		
Inlet pressure	0.07-2.0 MPa *1 (0.2 MPa or less for steam for washing or sterilization)		
Reduced pressure	(A) Yellow spring: 0.02-0.1 MPa <Standard setting: 0.05 MPa> (B) Red spring: 0.1-0.25 MPa <Standard setting: 0.1 MPa> (C) Black spring: 0.25-0.5 MPa <Standard setting: 0.3 MPa>		
Minimum differential pressure	0.05 MPa		
Maximum pressure reduction ratio	20:1		
Fluid temperature	5-90°C (The maximum temperature of steam for washing or sterilization is 130°C. Allow an interval of at least four hours between steam flows.)		
Material	Body	Cast Stainless steel (SCS14A)	
	Valve disc	Special synthetic rubber (special FKM)	
	Diaphragm	Heat-resistant synthetic rubber and PTFE (PTFE applied to wetted face)	
Connection	JIS Rc screwed	JIS 10K FF flanged	JIS 20K RF flanged

*1 The inlet pressure of GD-43G-10 is 0.07 to 1.0 MPa.

- If using for washing steam or sterilization steam, be sure that maximum temperature is 130°C and avoid continuous use for more than 30 minutes.
- Available with pressure gauge (JIS Rc 1/8 screwed).



■ Dimensions (mm) and Weights (kg)

• GD-41G

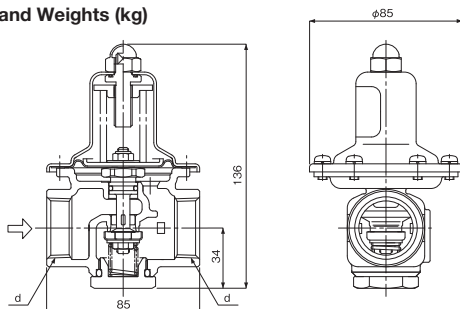

Nominal size	d	Weight
15A	Rc 1/2	1.2
20A	Rc 3/4	1.1
25A	Rc 1	1.0

* All dimensions are same except connection size.

• GD-43G

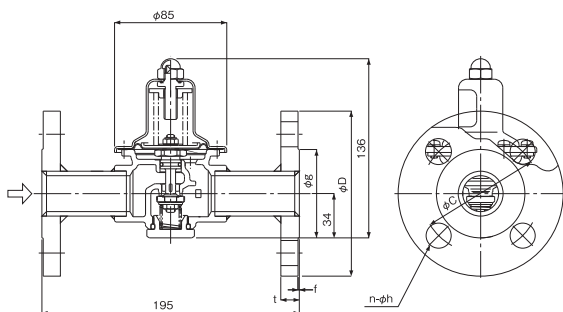

* All dimensions are same except flange size.

(mm)

Nominal Size	JIS 20KRF flange						Weight (kg)
	D	C	g	t	f	n-h	
15A	95	70	51	14 (12)	1	4-15	2.8 (2.6)
20A	100	75	56	16 (14)	1	4-15	3.0 (2.9)
25A	125	90	67	16 (14)	1	4-19	4.0 (3.7)

* The values in parentheses are the weights of the GD-43G-10.

Specifications Selection Chart

(Cold and hot water)

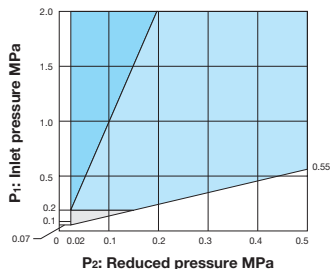

(Air, carbon dioxide gas, and nitrogen gas)

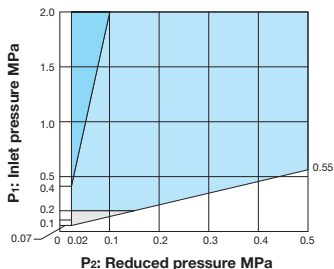

- Controllable range
- Range requiring two-stage pressure reduction
- Range controllable and also compatible with steam for washing or sterilization

Flow Characteristic Chart

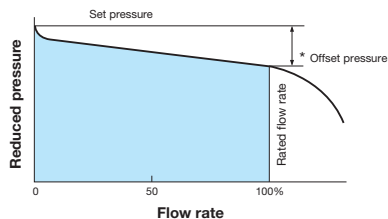

* Offset pressure

Set pressure	Offset pressure
0.2 MPa or less	Within 0.05 MPa
More than 0.2 MPa	Within 0.08 MPa

Pressure Characteristic Chart

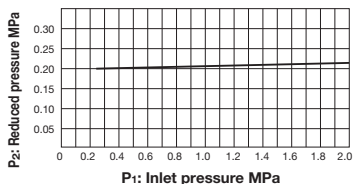

This chart shows variation in reduced pressure when the inlet pressure of 0.25 MPa is changed to 2.0 MPa while the reduced pressure is set at 0.20 MPa.

■ Nominal Sizes Selection Chart (For Air)

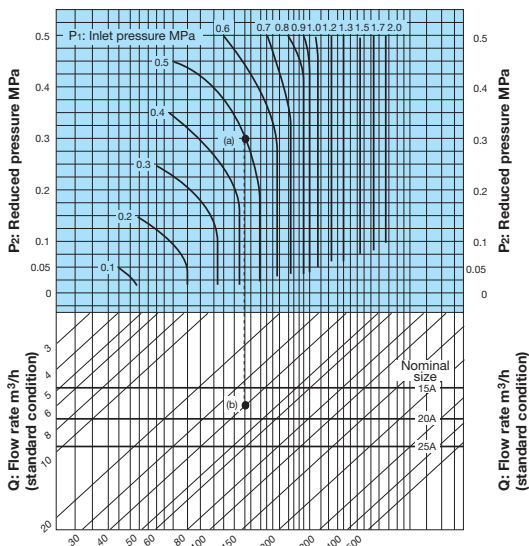

[Example]

When selecting the nominal size of a pressure reducing valve whose inlet pressure (P_1), reduced pressure (P_2), and flow rate are 0.5 MPa, 0.3 MPa, and 40 m^3/h (standard condition), respectively, first find intersection point (a) of the inlet pressure of 0.5 MPa and the reduced pressure of 0.3 MPa. Trace down vertically from this intersection point to find intersection point (b) with the flow rate of 40 m^3/h (standard condition). Since intersection point (b) lies between nominal sizes 15A and 20A, select the larger one, 20A.

* Set the safety factor at 80 to 90%.

■ Nominal Sizes Selection Chart (For Cold and Hot Water)

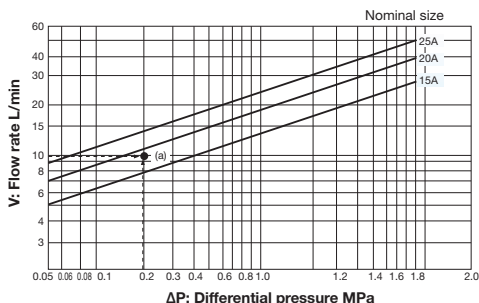

[Example]

When selecting the nominal size of a pressure reducing valve whose inlet pressure (P_1), reduced pressure (P_2), and flow rate are 0.5 MPa, 0.3 MPa, and 10 L/min, respectively, trace up vertically from the 0.2 MPa point of differential pressure before and after the valve to find intersection point (a) with the flow rate of 10 L/min. Since intersection point (a) is between nominal sizes 15A and 20A, select the larger one, 20A.